



LITHIUM IRON PHOSPHATE (LiFePO<sub>4</sub>)

RECHARGEABLE BATTERIES  
DEEP CYCLE



---

# 24V LITHIUM IRON PHOSPHATE BATTERY PACK

**MBL24-105**  
**24V 105Ah 2668Wh**



---

# Contents

1. Summary.....	3
2. Technical Specification.....	3
2.1. Battery Pack Specification .....	3
2.2. Protection Board Specification .....	4
3. Battery Pack Structure Description.....	5
3.1. Cell Module .....	5
3.2. Protection Board.....	5
3.3. Shell .....	5
3.4. Using .....	5
4. Appearance.....	6
4.1. View .....	6
4.2. Dimensional drawing .....	6
5. Storage and Transportation .....	7
5.1. Storage .....	7
5.2. Transportation .....	7
6. Warning and Tips.....	7



## 1. Summary

This 24V Lithium Iron Phosphate battery pack is widely used in Energy Storage System, Instrument, Medical Equipment, Financial/Commercial Equipment, Security/Electric Power Equipment, Robot etc. It could replace 12V Lead Acid battery pack, it is environmentally-friendly, and with long service life. This article mainly describes its appearance, size, electrical specifications, warning and tips, etc.

## 2. Technical Specification

### 2.1. Battery Pack Specification

No.	Item	Unit	Value	Remark
01	Cell Model	-	LFP-3.2V 105Ah	Prismatic Cell
02	Combination Mode	-	1P8S	
03	Nominal Capacity	Ah	105	
04	Rated energy	Wh	2668	
05	Initial Internal Resistance	mΩ	<150	AC 1KHz
06	Rated Voltage	V	25.6	
07	Recommended charging voltage	V	28.4(MAX29.2V)	Unit cell max. charge voltage not exceed 3.65V
08	Discharge Cut-off Voltage	V	20	Unit cell min. discharge voltage not lower than 2.5V
09	Standard Charge Current	A	20	0.2C
10	Max. Charge Current	A	≤100	1C
11	Standard Discharge Current	A	50	
12	Max. Discharge Current	A	≤100	
13	-20℃ Discharge Capacity		≥65% Nominal Capacity	
14	Cycle life	-	≥3500 times	DOD>80%
15	Operating Temperature	℃	-0~+55℃	Charge
			-20~ +55℃	Discharge
16	Open Circuit Voltage	V	20-29.2	
17	Shell type	-	ABS Plastic Shell	
18	Weight	kg	25	About
19	Dimension	mm	483(L)*170(W)*240(H)	Exclude wiring terminal

**2.2. Protection Board Specification**

No.	Item	Unit	Value	Remark
01	Overcharge Protection Voltage	V	3.85V ± 25mV	Single Series Protection
02	Overcharge Protection Release Condition	V	3.65V ± 50mV	
03	Over Discharge Protection Voltage	V	2.3 ± 80mV	Single Series Protection
04	Over Discharge Protection Release Condition	V	2.5 ± 100mV	
05	Discharge Over Current Protection	A	400A ± 50A	
06	Discharge Over Current Delay Time	mS	50-200	
07	Discharge Over Current Release Condition	-	Cut off load	
08	Short Circuit Protect Condition	-	External Short Circuit	
09	Short Circuit Protect Delay Time	uS	200-800	
10	Short Circuit Protect Release Condition	-	After cutting off load, switch activate.	
11	High Temperature Protect	°C	70 ± 5°C	-
12	High Temperature Protect Release Condition	°C	50 ± 12°C	



### 3. Battery Pack Structure Description

#### 3.1. Cell Module

This 1P8S cell module is made by 8pcs prismatic Lithium Iron Phosphate Cell.

#### 3.2. Protection Board

It protects and manages the battery's charge and discharge, provides protection against overcharge, over discharge, current overload, high temperature, short circuit, and could achieve cell balance.

#### 3.3. Shell

ABS plastic shell, standard size shell, convenient to replace.

#### 3.4. Using

Allow series with maximum 2 packs. Each pack should be charged fully before series.

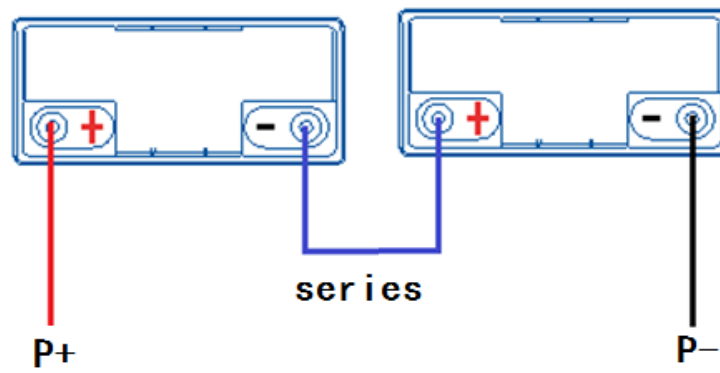



## 4. Appearance

### 4.1. View



### 4.2. Dimensional drawing

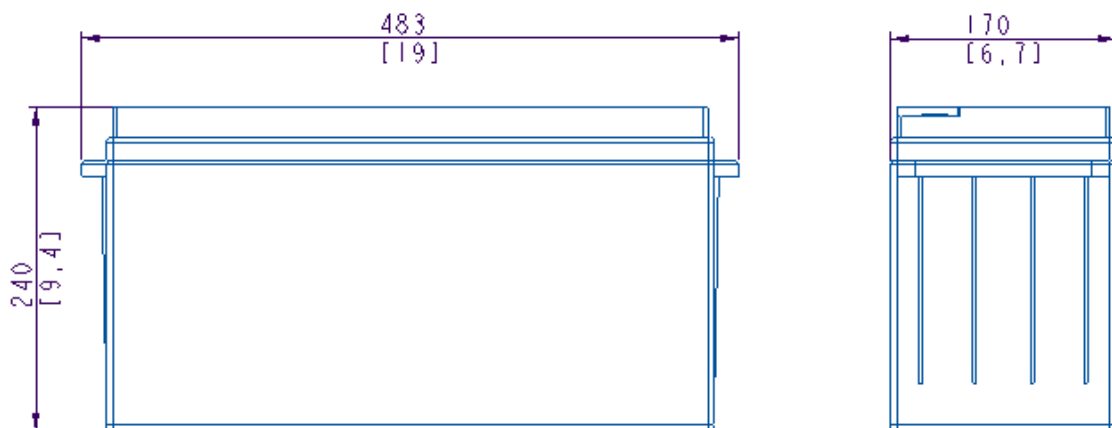



---

## 5. Storage and Transportation

### 5.1. Storage

When the product is not in use for a long time, please put it in a dry and ventilated place to avoid inflammable and explosive articles; charge and maintain the battery pack regularly every three months to ensure that the battery is in the best performance state.

### 5.2. Transportation

Battery pack should be packed with outer packing before they can be transported. In the course of transportation, severe shock, shock or extrusion should be prevented, and sunshine and rain should be prevented.

## 6. Warning and Tips

6.1. Never put batteries in water or wet them.

6.2. It is forbidden to charge and use batteries outside the temperature range we prescribe. Do not store, charge and use this product near the source of fire or heat.

6.3. When the battery pack emits odor or leaks, it should stop using or charging immediately, and move to an open ventilated place, away from the source of fire, and contact us in time.

6.4. Do not connect the positive and negative poles in connection with the load.

6.5. Do not short-circuit the positive and negative poles of the battery pack with metal conductors

6.6. Do not put the battery pack into the fire or heat it.

6.7. It is strictly forbidden to dissect the battery pack artificially, to pierce the battery pack with nails or sharp objects, to strike the battery pack with hammers or other external forces, and to trample and drop the battery pack artificially.

6.8. It is strictly forbidden to put batteries in microwave ovens or pressure vessels.

6.9. If any abnormal phenomena occur during charging or using, please stop charging and using immediately.

6.10. The optimum operating temperature of the product is  $25\pm 5^{\circ}\text{C}$ . If the product is not in this temperature range in the course of using, the discharge capacity will be reduced.

6.11. If any malfunction or abnormality occurs during the use, please contact us and do not disassemble the battery pack without permission.

6.12. The above test is for new batteries whose arrival time is not more than one month.